



CONSERVATION EASEMENTS:

Fiscal Impacts to Localities in the Middle Peninsula



This map was funded in whole by the Virginia Coastal Zone Management Program at the Department of Environmental Quality through Grant # NA10NOS4190205 Task 97.01 and Task 95 of the U.S. Department of Commerce, National Oceanic and Atmospheric Administration, under the Coastal Zone Management Act of 1972, as amended. The views expressed are those of the author(s) and do not necessarily reflect the views of the U.S. Department of Commerce, NOAA, or any of its subagencies.

Jackie Rickards
Middle Peninsula Planning District Commission
July 13, 2011

Location of the Middle Peninsula

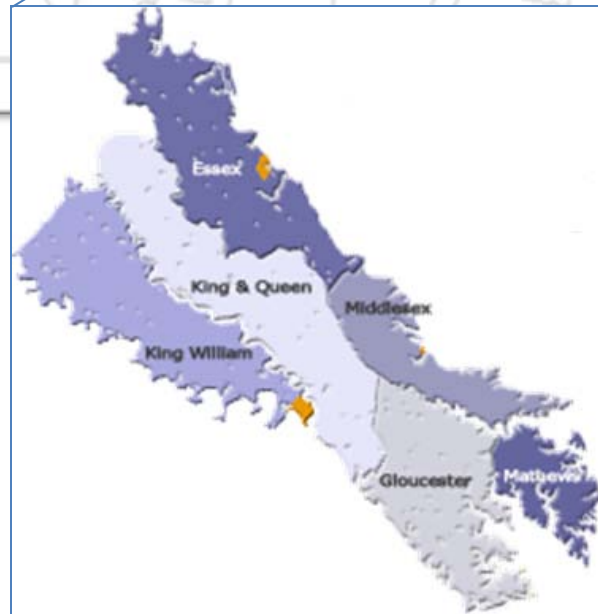
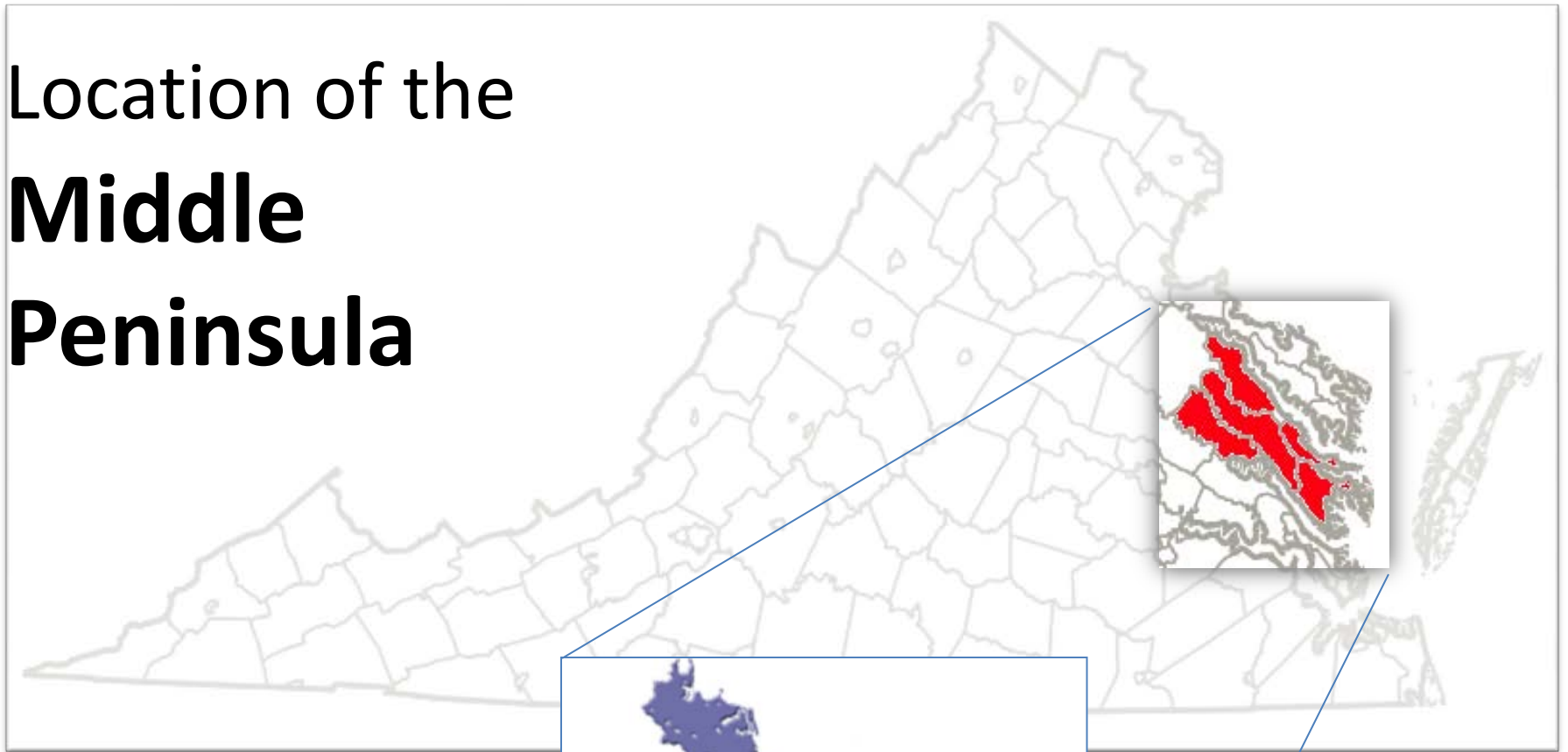

Middle Peninsula Landscape

Coastal



Forestal/Silviculture



Agriculture

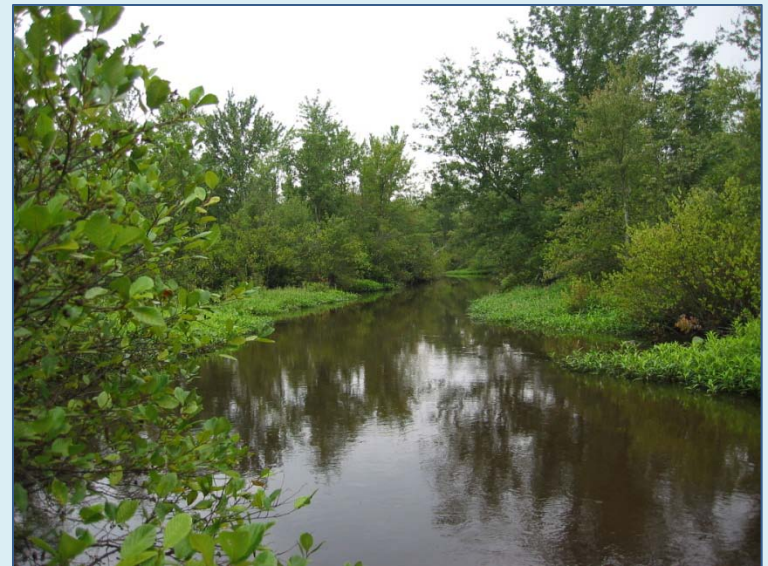

Dragon Run, King & Queen County 3



Background

- Dragon Run Steering Committee (DRSC) promotes conservation easements
- Significant focus on conservation easements and land holding
- Difficult economic times
- Localities' concern over fiscal impacts of conservation easements and land holdings
- DRSC and MPPDC resolutions to study and help promote policy changes



Phase 1-

Project Goals

1. Understand the impact of conservation easements and tax exempt land holdings on local tax revenue
2. Understand the cost of public services in open lands compared to developed lands
3. Understand the process by which easements are valued
4. Identify policy changes to help Commissioners of Revenue improve consistency
5. Maximize county fiscal benefit from composite index

Bundle of Sticks Theory

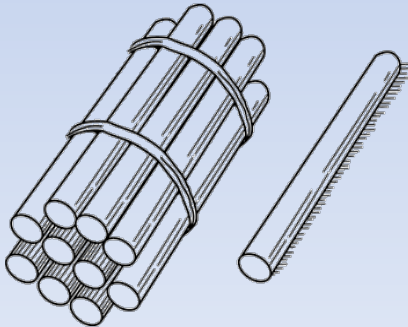
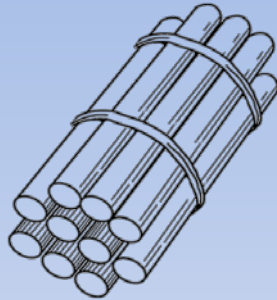

1. The bundle of sticks represents all rights of fee simple ownership

2. With conservation easements, one stick is removed from the bundle. This represents the rights limited by the easement. This stick is given to an eligible conservation easement holder.



Rules of the Road

Open-Space Land Act 1966

Public Bodies

10.1-1700 – 10.1-1705

Virginia Conservation Easement Act 1988

Non-Profits

10.1-1009 – 10.1-1016

Virginia Conservation Easement Act: 10.1-1011 Taxation

B. Assessments of the fee interest in land that is subject to a perpetual conservation easement held pursuant to this chapter or the Open-Space Land Act shall reflect the reduction in the fair market value of the land that results from the inability of the owner of the fee to use such property for uses terminated by the easement.

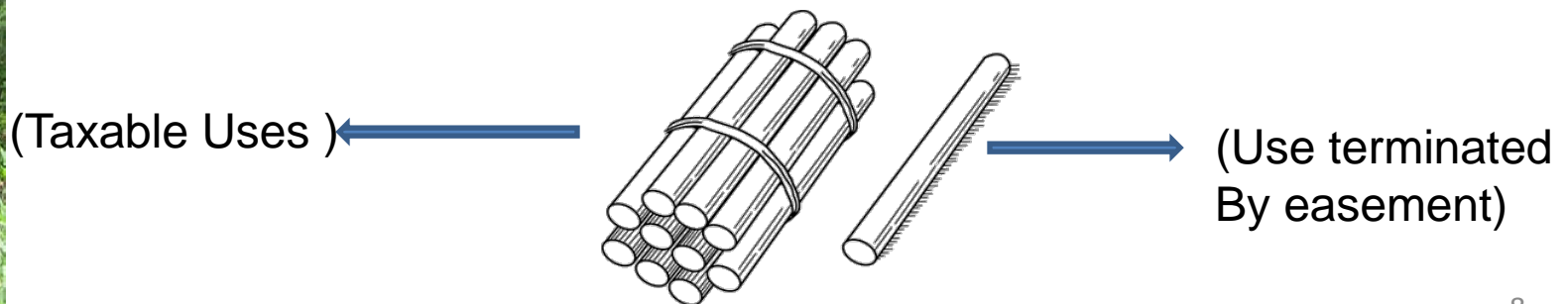

10.1-1011 Taxation

Guidance for Non-Land Use Localities

B. ...shall reflect the reduction in the fair market value of the land that results from the inability of the owner of the fee to use such property for uses terminated by the easement. To ensure that the owner of the fee is not taxed on the value of the interest of the holder of the easement, the fair market value of such land

(i) shall be based only on uses of the land that are permitted under the terms of the easement and (ii) shall not include any value attributable to the uses or potential uses of the land that have been terminated by the easement

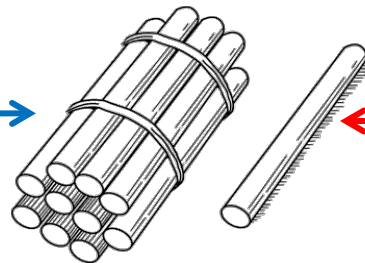

This means.....

Establishing a fair market value for properties with conservation easements in Non Land Use Counties:

1. Value is determined may be determined by a qualified assessor, which is then accepted by the locale as the assessed value.
2. Value is established by the assessor but the Commissioner of Revenue would then have the final word as to the fair market value

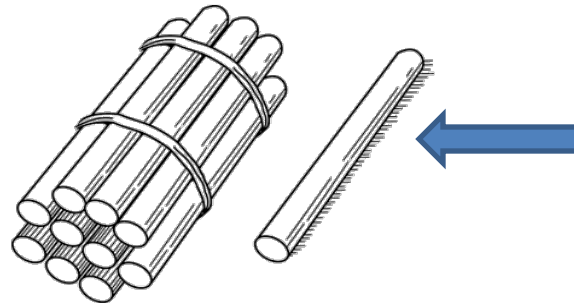

Value is determined by the assessor and/or Commissioner of Revenue

Total value of property may go up, down or stay neutral depending on real estate market dynamics

Non Land Use Program King & Queen, Mathews

Scenario #1: Assessment Value

1. Ms. Smith owns 100 acres.



Her land is assessed at
\$150,000



The assessment value is taxed. Thus, with a tax Levy of \$0.57/\$100...

$$\left(\frac{\$150,000}{\$100} \right) \times \$0.57 =$$

\$855.00 is due

The Commissioner of Revenue will record

\$150,000

in the Land Book

Scenario #2: Conservation Easements

2. Ms. Smith now wants to put all 100 acres in a conservation easement.

If a CoR chooses to reduce the FMV by 25% then....

1. Tax exempt rights with easement will be valued at
\$37,500

2. The taxable rights, the remaining bundle of sticks, will have a value of
\$112,500

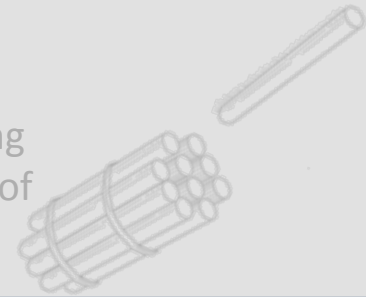

Mr. Jones's will be taxed based on the land use value of the land. With a tax Levy of \$0.57/\$100...

$$\left(\frac{\$112,500}{\$100} \right) \times \$0.57 = \$641.25 \text{ is due}$$

The Commissioner of Revenue will record

\$112,500

in the Land Book

Non Land Use Program King & Queen, Mathews

Scenario #1: Assessment Value

1. Ms. Smith owns 100 acres.



Her land is assessed at
\$150,000

Scenario #2: Conservation Easements

2. Ms. Smith now wants to put all 100 acres in a conservation easement.

If a CoR chooses to reduce the FMV by 25% then....

1. Tax exempt rights with easement will be valued at
\$37,500

2. The taxable rights, the remaining bundle of sticks, will have a value of **\$112,500**

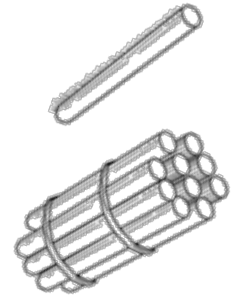

The assessment value is taxed. Thus, with a tax Levy of \$0.57/\$100...

$$\left(\frac{\$150,000}{\$100} \right) \times \$0.57 =$$

\$855.00 is due



Mr. Jones's will be taxed based on the land use value of the land. With a tax Levy of \$0.57/\$100...

$$\left(\frac{\$112,500}{\$100} \right) \times \$0.57 = \text{\$641.25 is due}$$

Tax Revenue
Generated

Recorded
land book
Value

The Commissioner of Revenue will record

\$150,000
in the Land Book

The Commissioner of Revenue will record

\$112,500
in the Land Book

10.1-1011 Taxation

Guidance for Land Use Localities

C. ...in any county, city or town which has provided for land use assessment and taxation of any class of land within its jurisdiction pursuant to [58.1-3231](#) or [58.1-3232](#), **shall be assessed and taxed at the use value for open space, if the land otherwise qualifies for such assessment at the time the easement is dedicated.** If an easement is in existence at the time the locality enacts land use assessment, the easement shall qualify for such assessment. Once the land with the easement qualifies for land use assessment, it shall continue to qualify so long as the locality has land use assessment.

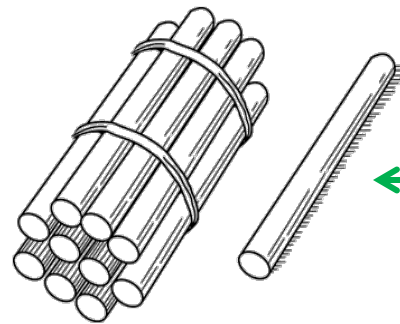

Because of the stick, the land eased receives the land use value

This means.....

In Land Use Counties, the Commissioner of Revenue must determine the use value under the land use program and shall be assessed and taxed as such

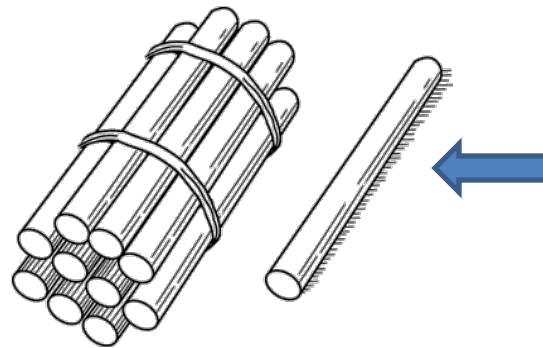

Assessed value dictated by the county's land use program

Total value of property may go up, down or stay neutral depending on real estate market dynamics



Attorney General's Opinion

November 19, 1993

to the honorable Joyce L. Clark, Commissioner of Revenue for Orange County, VA

***Question 3:** If a locality has adopted a use value assessment program that does not cover forest or open space uses, would land under such easement that is used for forest or open-space purposes qualify for open-space use assessment?*

Answer: if a locality has a use value program that does not cover forest and open-space uses, land under conservation or open-space easement used for forest or open-space still will qualify for the open-space use value assessment. Land encumbered by such a perpetual easement meets the definition requirements in 58.1-3230 being “preserved for...conservation of land or other natural resources...or scenic purposes.” Section 10.1-1011, reflects the General Assembly’s conclusion that this tax treatment is appropriate, because the owners of land that is subject to such open-space or conservation easements permanently have protected open space and thus permanently have given up part of their land’s value.

Land Use Program

Essex, King William, Gloucester, Middlesex

Scenario #1: Land Use Value

1. Mr. Jones owns 100 acres.



His land is assessed at
\$150,000

But, the Land use rate for agriculture land is **\$550/acre**

Therefore, the land use value of the land is

\$55,000



The land use value is taxed. Therefore with a tax levy of \$0.57/\$100...

$$\left(\frac{\$55,000}{\$100} \right) \times \$0.57 =$$

\$313.50 is due

The Commissioner of Revenue will record

\$150,000

in the Land Book

Scenario #2: Conservation Easements

2. Mr. Jones now wants to put all 100 acres in a conservation easement.

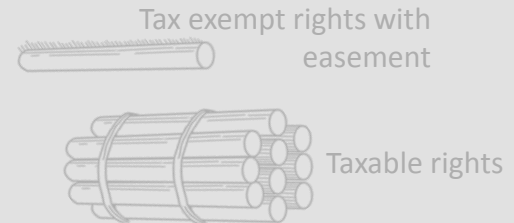

One stick removed from the bundle represents the rights limited by the easement.

In accordance with VA Tax Code 10.1-1011, Mr. Jones's land under easement will have a fair market value equal to the land use value of

\$55,000



Mr. Jones's will be taxed based on the land use value of the land. With a tax levy of \$0.57/\$100...

$$\left(\frac{\$55,000}{\$100} \right) \times \$0.57 = \mathbf{\$313.50}$$
 is due

The Commissioner of Revenue will record

\$55,000

in the Land Book

Land Use Program Essex, King William, Gloucester, Middlesex

Scenario #1: Land Use Value

1. Mr. Jones owns 100 acres.



His land is assessed at
\$150,000

But, the Land use rate for agriculture land is **\$550/acre**

Therefore, the land use value of the land is

\$55,000



The land use value is taxed. Therefore with a tax levy of \$0.57/\$100...

$$\left(\frac{\$55,000}{\$100} \right) \times \$0.57 =$$

\$313.50 is due

The Commissioner of Revenue will record

\$150,000

in the Land Book

Scenario #2: Conservation Easements

2. Mr. Jones now wants to put all 100 acres in a conservation easement.

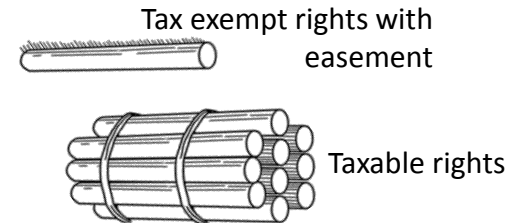

One stick removed from the bundle represents the rights limited by the easement.

In accordance with VA Tax Code 10.1-1011, Mr. Jones's land under easement will have a fair market value equal to the land use value of

\$55,000



Mr. Jones's will be taxed based on the land use value of the land. With a tax levy of \$0.57/\$100...

$$\left(\frac{\$55,000}{\$100} \right) \times \$0.57 = \mathbf{\$313.50}$$
 is due

The Commissioner of Revenue will record

\$55,000

in the Land Book



**PROPERTY ASSESSMENT,
TOTAL LAND BOOK VALUE,
COMPOSITE INDEX
and their
CONNECTION**

Flow of information :

Commissioner of Revenue's objective is to maintain a land book and generate a total land book value . This value is ultimately used as a factor in the composite index

1

Locality
Commissioner of
Revenue

The VaTAX sends the Department of Education a copy of the annual sales ratio study and the Total Land Book Value.

2

Virginia Department
of Taxation

Department of Education will generate the composite index which reflects a county's ability to pay education cost.

3

Virginia Department
of Education (for the
composite index)

Total Value of Land Book

True Value of Property
Sales Ratio Study



What's the problem.....

The Commissioners of Revenue may be over reporting the total land book value



Not maximizing localities' state aid under the Composite Index

Composite Index Factors

- True value of real property (weighted 50%)
- Adjusted gross income (weighted 40%)
- Taxable retail sales (weighted 10%)

Example 1 – Middlesex County (LU)

Owner

Owner Address

1
DELTAVILLE VA
, 23043

Total Land Area

52.318 Acres
Land Use Value
\$29,200

Property Address

1172 NORTH END RD
DELTAVILLE, VA 23043

Legal Description(s)

NORTH END
52.318 AC (LUCA)
D118-455,P457,471,199-757,416-583
D299-406,P14-284,P16-484

Zoned

R

Prior Assessment

\$497,500

Magisterial District

PINE TOP

Deed Bk/Pg

299 / 406

Remarks

Assessment Values (Map#: 40 8C)

No Building	0
Land Value:	\$1,133,300
Other Improvements:	0
Total Value:	\$1,133,300

Acreage Description (Map#: 40 8C)

Size In Acres	Description	Lump Sum or Per Acre	Unit Value	Adj. %	Utility Value	Acreage Value
1.00	Homesite	Lump Sum	800,000	0.00		\$800,000
2.00		Per Acre	100,000	0.00		\$200,000
2.96		Per Acre	9,000	0.00		\$26,640
46.358		Per Acre	2,300	0.00		\$106,623

Total Value: \$1,133,263

Example 2 – Essex County (LU)

Property Address

0 PASSING RD (OFF)

Map#: 9 40

Acct#: 665-1

Owner Name/Address

PINE HILL LLC
C/O TOM DESHAZO
94 HOLLYWOOD FARM RD
FREDERICKSBURG VA 22405

Legal Description: CEDAR GROVE (PART)

Occupancy: VACANT

Dwelling Type:

Use/Class: SNGL FAM RES - SUBURBAN

Year Assessed: 2008

Zoning: AGRICULTURAL

District: 01 OCCUPACIA

MH/Type:

Condition:

Inst#: 07 0 1209 00

Plat Bk/Pg: 24/65

Acreage: 19.330

Year Built: 0

Year Rmld:

Year Eff:

On Site Dte: 11/21/2006

Review Date: 10/10/2007

Land Use: 0

Tot. Mineral:

Total Land: 9700

Total Imp.:

Total Value: \$9,700

Improvement Description			Site
Exterior	Interior		
			STRT-NO FUR RD
			TOPO-SLOPE

Land Valuation								
Meth	Cls	Desc	Grd	Size	Depth	Rate	FV/Pct	Value
A	19	WOOD/OFFRD	E	19.330		2400.00	36727-	9665
Total Land Value				19.330				9700

Comments	
2007:	FR ROBERT G & MARILYN G FOGG (DBS 07-1209)
2008:	19.33 AC CHANGE (PB 24-65)
2008:	CONSERVATION EASEMENT (DB 08-1418)
2009:	ECON DEPR -25% (CONSERVATION EASEMENT)
2009:	LAND USE
2010:	ECON DEPR -36,727 (CONSERVATION EASEMENT)
2010:	REMOVED FROM LAND USE (CONSERVATION EASEMENT)
Total Property Value	
	9700

Sec	Type	Str	Description	Area
			Cur. Value	Prev. Value
Land			9700	11000
Improvements				
Total			9700	11000
Average Price Per Acre			2400	
Sale Date/Amount			5/23/2007	36000

Example 2 – Essex County (LU)

Property Address

0 PASSING RD (OFF)

Map#: 9 40

Acct#: 665-1

Owner Name/Address

PINE HILL LLC
 C/O TOM DESHAZO
 94 HOLLYWOOD FARM RD
 FREDERICKSBURG VA 22405

Legal Description: CEDAR GROVE (PART)

Occupancy: VACANT

Inst#: 07 0 1209 00

Dwelling Type:

Plat Bk/Pg: 24/65

Use/Class: SNGL FAM RES - SUBURBAN

Acreage: 19.330

Year Assessed: 2008

Year Built: 0

Land Use: 0

-----Land Valuation-----

Math	Clas	Desc	Grd	Size	Depth	Rate	FV/Pct	Value
A	19	WOOD/OFFRD	E	19.330		2400.00	36727-	9665
Total Land Value				19.330				9700

-----Comments-----

- 2007: FR ROBERT G & HARILYN G FOGG (DBS 01-1209)
- 2008: 19.33 AC CHANGE (PB 24-65)
- 2008: CONSERVATION EASEMSNET (DE 08-1418)
- 2009: ECON DEPR -25% (CONSERVATION EASEMENT)
- 2009: LAND USE
- 2010: ECON DEPR -36,727 (CONSERVATION EASEMENT)
- 2010: REMOVED FROM LAND USE (CONSERVATION EASEMENT)

Total Property Value 9700



Phase I: **Findings**

Regional Summary

	Acres under Conservation Easements	Acres held by Tax-exempt Conservation Entities	Acres Conserved Total	Tax Revenue Loss due to Conservation Easements	Tax Revenue Loss due to Tax-exempt Conservation Land Holdings	Total Tax Revenue Loss	Percentage of the County's Budget
Middlesex	4,291	521	4,812	\$37,778	\$5,428	\$43,206	.18%
Gloucester	1,010.02	3,114.95	4,124.97	\$32,406	\$16,779	\$49,185	.0005%
Essex	12,343.81	1,170.18	13,514	\$115,288	\$14,790	\$130,078	.44%
King William	6,729.3	2,630.09	9,359.39	\$59,893	\$53,500	\$113,393	.54%
King and Queen	14,156.45	12,971.25	27,127.70	\$14,953	\$64,007	\$78,960	.39%
Mathews	341	257.97	598.97	\$1,107	\$1,836	\$2,942	.01%
Regional Total	38,872	20,665	59,537	\$262,974	\$156,340	\$419,313	-



Capturing Conservation Easements: additional fiscal benefits

	Additional Devaluation due to easements	VaTax Sales Ratio Study	True Value of Property over reported
Middlesex	\$10,793,682	79.53%	\$13,571,837
Gloucester	\$5,587,222	85.11%	\$6,564,707
Essex	\$18,594,806	95.23%	\$19,526,206
King and Queen	\$3,115,224	70.00%	\$4,450,320
King William	\$7,394,152	89.89%	\$8,225,778
Mathews	\$197,600	62.56%	\$315,857

Virginia Department of Taxation Sales Ratio Study – Determines the relationship between the assessed value of real estate and what properties have actually sold for during the past year.



Phase 1-

Identified Problems

- 10.1 (Conservation) vs 58.1 (Taxation)
- No standard administrative mechanism to “capture” the recordation of conservation easements
- The Commissioners of Revenue are provided limited or no guidance on valuing easements or reporting for the purposes of maximizing composite index aid
- Different approaches to valuing easements depending on the locality
- Some data does not transfer between reassessments
- Not maximizing composite index return for state aid for schools



Phase 1-

Key Findings

- Conservation easement impacts are a very small percentage of a county's budget – Less than 0.5%
- Easements lower land value and thereby should help increase state aid from the composite index



Phase I – **Outcomes**

- Changing assessment process (land use counties especially) to capture additional state aid through composite index
- Updated lists of conservation easements for reassessments
- Changing internal process to stay abreast of conservation easements
- Applying a generally more consistent approach to assessing eased lands



Phase II:
Land Use Impacts



Is there a disconnect between what our planning tools encourage and what our elected officials value currently and what our conservation community is accomplishing?

Promote agriculture
and forestry

Preserve Rural
Character

Chesapeake Bay and Water Quality
Values

Zoning Incompatible/ Compatible with Conservation and Currently Protected Areas within the Middle Peninsula

Legend:

 Protected Areas (ie. Managed land and lands with Conservation easements)

 Zoning Incompatible with Conservation

 Zoning Compatible with Conservation



Virginia Coastal Zone
MANAGEMENT PROGRAM



This map was funded in whole by the Virginia Coastal Zone Management Program at the Department of Environmental Quality through Grant # NA10NOS4190205 Task 97.01 of the U.S. Department of Commerce, National Oceanic and Atmospheric Administration, under the Coastal Zone Management Act of 1972, as amended. The views expressed are those of the author(s) and do not necessarily reflect the views of the U.S. Department of Commerce, NOAA, or any of its subagencies.

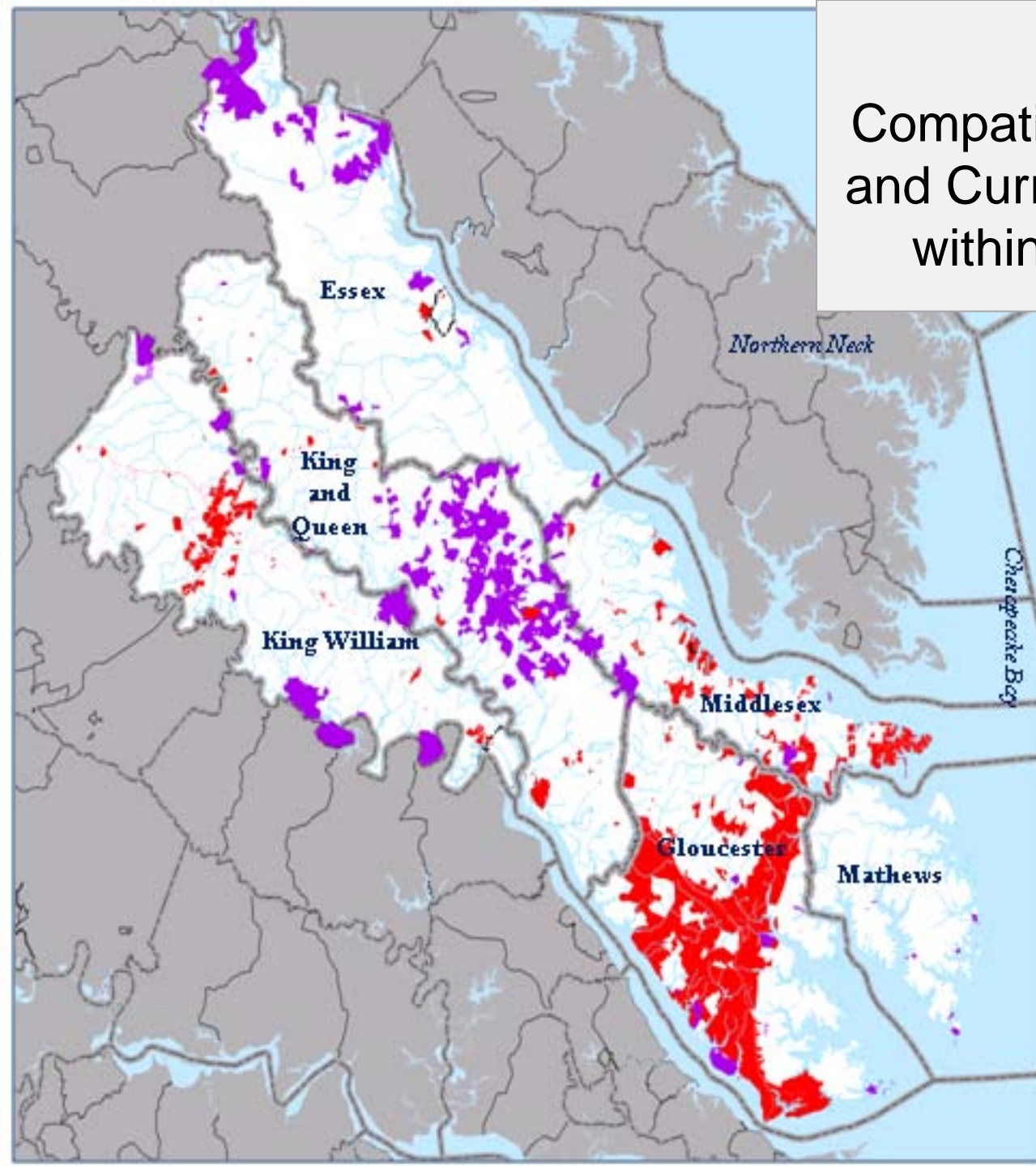



VCEA 10.1-1010.

Creation, acceptance and duration

E. No conservation easement **shall be valid and enforceable** unless the limitations or obligations created thereby **conform in all respects to the comprehensive plan** at the time the easement is granted for the area in which the real property is located.

PROBLEM: No formal approval or enforcement process



Enhancing accountability of Conservation Easements

- Stakeholder engagement
- Development of MOU
- Policy Recommendations
- Administrative Recommendations



Contact:

Jackie Rickards

Regional Projects Planner II

Middle Peninsula Planning District Commission

Phone: 804-758-2311

Email: jrickards@mppdc.com